



1 T to 5 T



Anti Heat Shield

Standard Features

- Rugged Heavy duty design, cast Aluminium alloy housing.
- Remote control - On/Off, Change, Zero, Hold.
- Heat shield - 100°C to 1600°C at distance of approx. 2.5 mtr.

Function

- ON/OFF, Change, Zero Set
- Display : 5 digit, 1.2" RED LED
- Zero Range : 4%FS.
- Max Safety Load : 250%FS.
- Ultimate load : 500%FS.

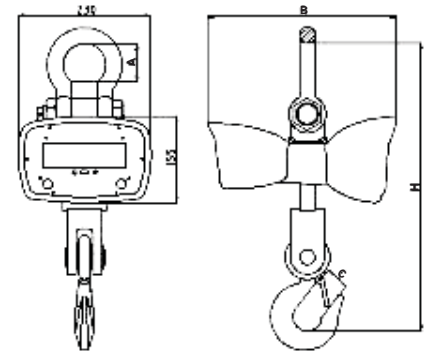

Construction

1. High special safety construction Load cell design to protect damage overload
2. Load Cell connects to upper ring & Bottom Hook, with Non-screw safety design to prevent loosen or breakage .
3. Easy operated wireless remote control. (distance 15m approx)

Crane Scale

HA Series

Dimension:

Model	A(mm)	B(mm)	C(mm)	H(mm)	N.W.
HA-1T	90	280	40	580	16kg
HA-2T	90	280	40	580	16kg
HA-3T	90	280	40	580	16kg
HA-5T	110	280	45	670	18kg
HA-10T	130	280	60	700	20kg

Model	HA 600	HA 1T	HA 2T	HA 3T	HA 5T	HA 10T	HA 15T	HA 20T	HA 30T	HA 50T	HA 100T
Capacity	600 kg	1 Ton	2 Ton	3 Ton	5 Ton	10 Ton	15 Ton	20 Ton	30 Ton	50 Ton	100 Ton
Graduation	200 g	200 g	500 g	1 kg	2 kg	5 kg	5 kg	10 kg	10 kg	20 kg	50 kg
Display	Rechargeable Battery 6V / 10Ah, Approx 100 Hours Backup Time.										
Power Supply	AC 230V + 10% 50-60Hz										