

Digital ABBE Refractometers

ARM Series



Feature

- Apparatus equipped with an optical system made of a telescope with dispersion correction, used to define the division line between dark and bright areas.
- Measurement of refractive index nD of transparent or translucent liquid and solid substances.
- Measurement of the Brix of sugar solutions.
- Prism made of hard glass.
- Precise optics with automatic temperature compensation Visual aim LCD display, as °Brix and sample temperature.
- Stabilized temperature connection for water bath. RS 232 output with software **Included**.

Refractometer is an indispensable regular instrument used in the petroleum industry, oil industry, pharmaceutical industry, paint industry, food industry, daily chemical industry, sugar industry and geological prospecting and other relevant factories, schools and research units.

Technical Description

1. Monocular system.
2. Telescope adjustment.
3. Digital display.
4. Mains switch "POWER".
5. Push Button "RED".
6. Push Button Brix with Temperature correction "Bx - TC".
7. Push Button for the refractive index "nD".
8. Push Button for Brix without temperature correction "Bx".
9. Optical Control.
10. Light intensity unit.
11. Refractometer prism.
12. Push button for Temperature indicating. "TEMP".

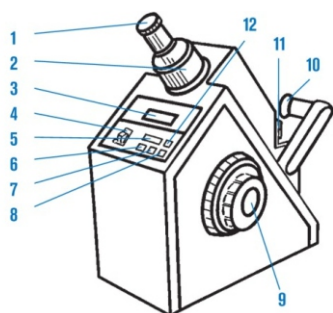

Standard Accessories Item

Supplied complete with dust cover and maintenance box that includes.

Item	Description	Qty.
1	Naphthalene Bromide	1
2	Calibration Standard	1
3	Hex key	1
4	Lamps 6.3V, 0.25A	3
5	Fuses 1A	3

Model	ARM - 2S
Measuring range	
Refractive index nD	1.3000 ~ 1.7000
Dissolved Solids Brix	0 ~ 95%
Accuracy	
Refractive index nD	≤±0.0002
Dissolved Solids Brix	≤±0.1%
Temperature range (Min. 0.1°C)	0 ~ 50°C
Correcting Range of Brix Versus Temperature	15 ~ 45°C
Usage Temperature Range	35°C
Power Requirements	230 Vac, ± 20%, 50-60Hz
Dimension (LxWxH)	3370 x 240 x 270mm
Weight Approx.	12 kg

WORLDWIDEMARKETING

ACZET PVT. LTD.

Unit E2, Plot No. 15, WICEL Estate, Opp Seepz Gate Nol. 1, Andheri (E), Mumbai 400 093. (INDIA)
 Tel. : +91-22-4243 7700 • Fax : +91-22-4243 7800 • E-mail : sales@aczel.com • Web : www.aczel.com